

APS-U Storage Ring Removal, Installation and Space Planning

Tom Fornek
APS-U Deputy Project Manager
PSC APS-U Project

Co-author Chuck Prokuski

APS-U Forum Meeting

23 April, 2015

Scope

- Removal and installation planning covers:
 - Storage ring and associated equipment removal
 - Transport of removed components to a disposition area
 - Installation of new storage ring and associated equipment
 - Integrated system testing
 - Commissioning
 - Space planning for staging and re-work

- Planning for and execution of these tasks dictates the length of time that APS is down.



Requirements and Constraints

- Target schedule for removal, installation and commissioning is one year.
 - In current APS Operations schedule, three months each year is allocated to maintenance.
 - Key performance parameters and CD-4 definition not yet settled, but 'meaningful beam' is the model.
 - Effect on design and testing has been discussed.
- Removal and Installation plan has been reviewed and cross checked with experience at other facilities.
- A survey of recent commissioning experience has been completed.

Hardware component and system test/preparedness are a driver of the overall schedule



Overview

- The APS Upgrade requires that the existing storage ring and the associated power and electronic systems be replaced. The storage ring is located in a tunnel, and the power and electronic systems are located on the mezzanine above the tunnel.
- The storage ring is 1104 m in circumference
 - Main access is through five “super doors” on the interior of the ring.
 - Some equipment can be accessed at two ratchet wall doors in each sector.
- Over 1900 tons of material will be removed and be replaced with over 3000 tons of new components.
- Necessary resources, equipment and facilities must be ready prior to the start of work.
- Planning was started early
 - We have to plan for installation – this drives component and system design in places.
 - Conceptual plan was reviewed in March 2014.
 - We continue to emphasize incorporation of design features for easy installation.



Overview - Mezzanine and Tunnel

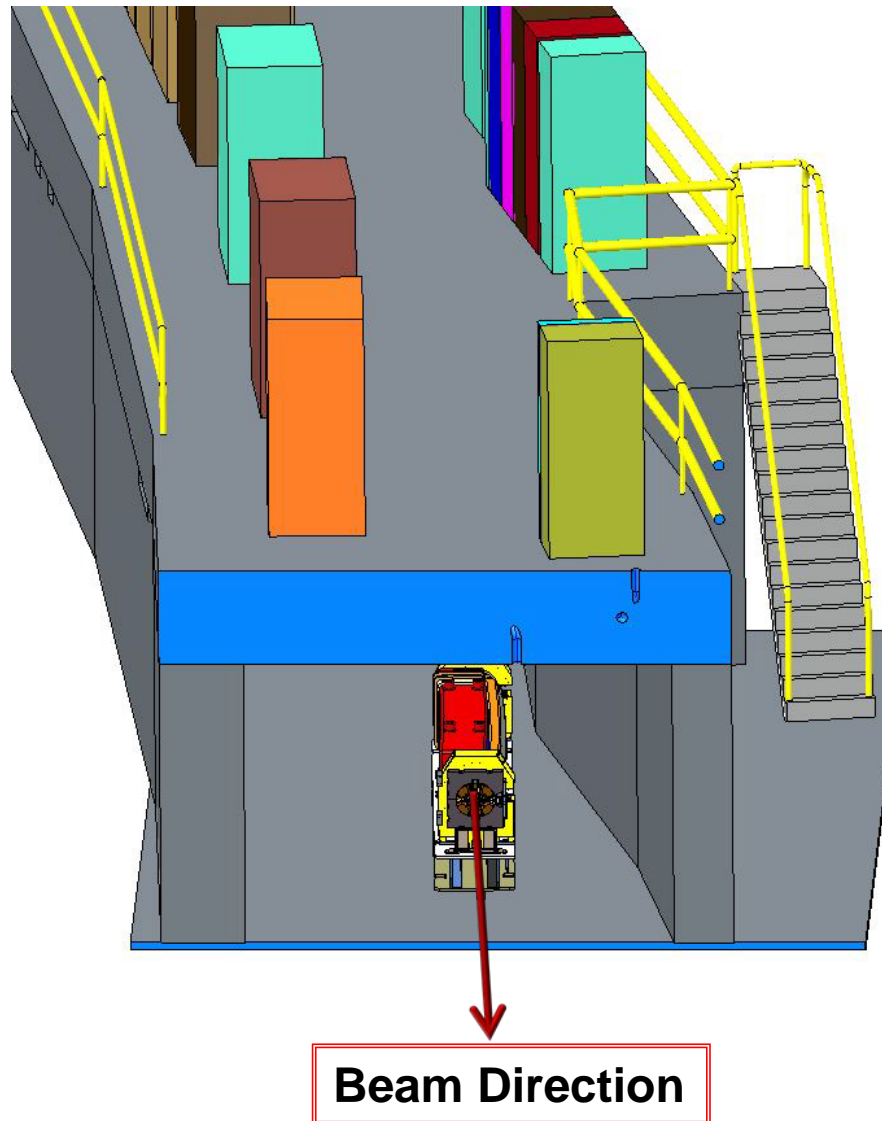

Overview - One Sector of the Existing Storage Ring

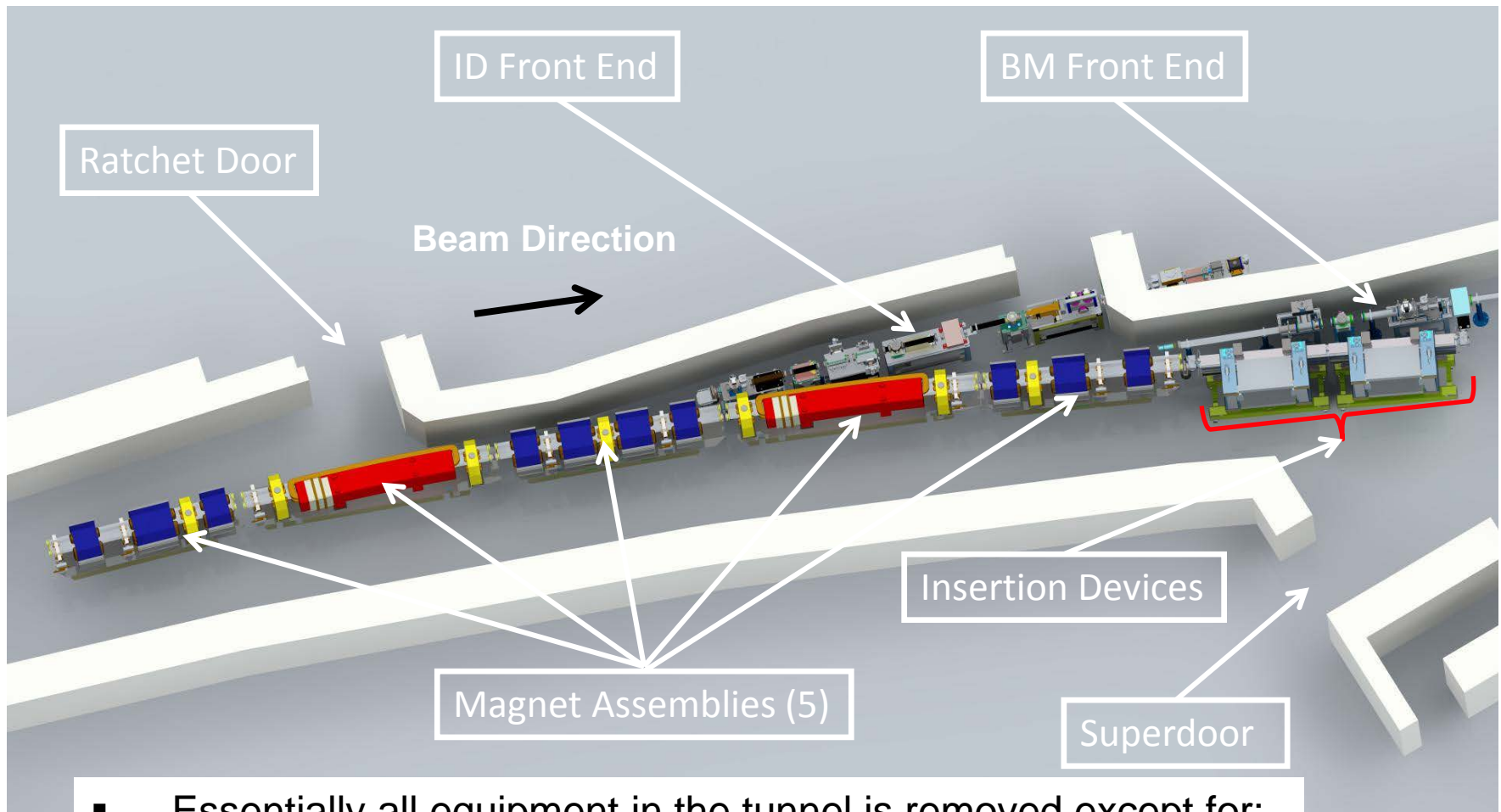

- Essentially all equipment in the tunnel is removed except for:
 - Fire safety systems
 - HVAC
 - Lighting and outlets



Electronics Removal and Installation on Mezzanine

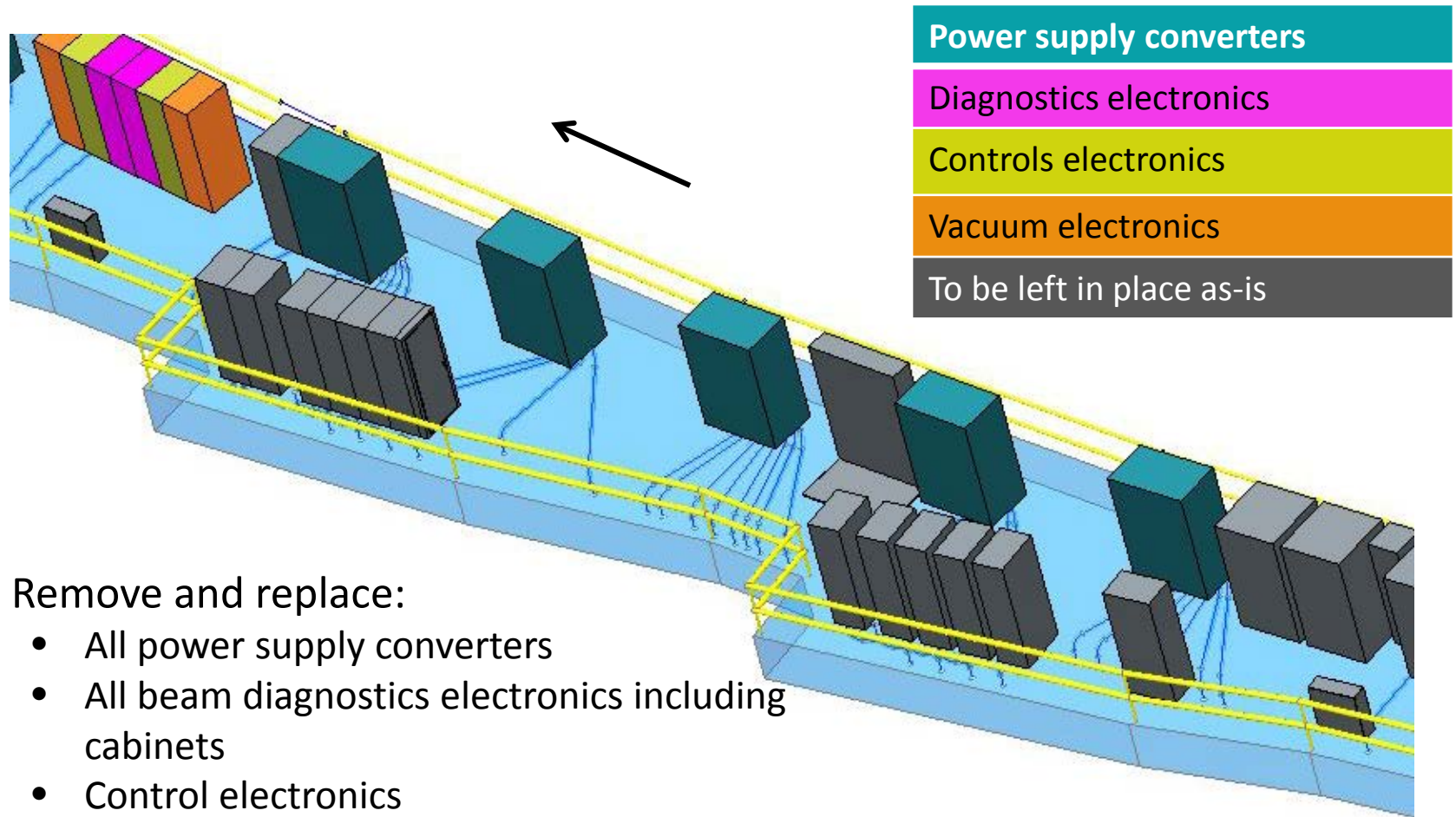

- Remove and replace:
 - All power supply converters
 - All beam diagnostics electronics including cabinets
 - Control electronics
 - Vacuum electronics
 - Cables and connectors



Storage Ring Removal

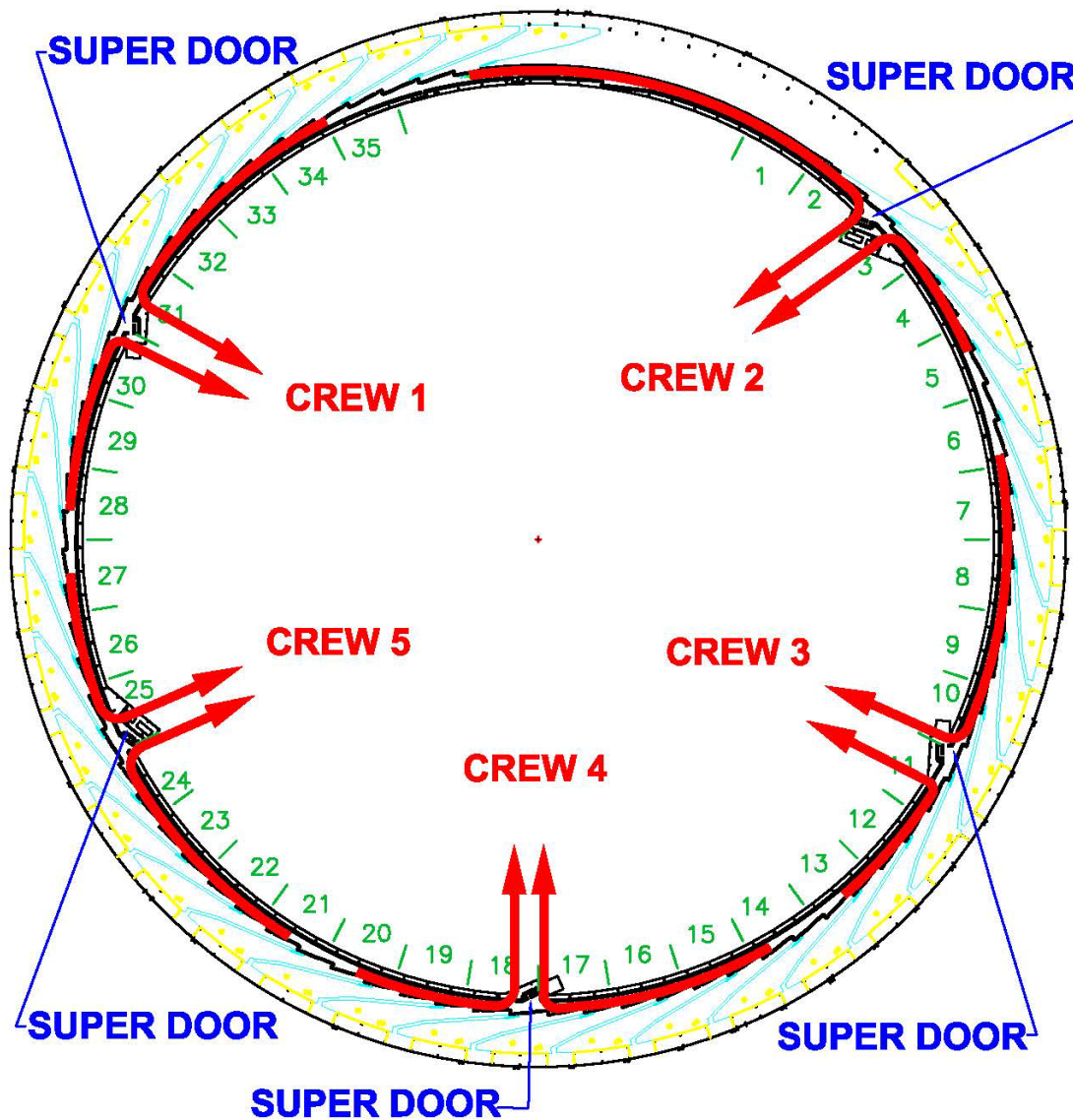

Each crew will use one of the five super doors on the infield side of the building.

Storage ring components will be removed starting at the super door and then outward progressively to roughly the mid-point between the super doors.

Removed materials will be trucked to the onsite disposition facility.



Insertion Device and Magnet Assemblies



All IDs will be removed first.

This is a semi-routine activity and along with the Front Ends we have very recent experience with these activities.

Magnet Assemblies to be removed

- 200 assemblies (five per sector) of three basic types:
 - Lengths: 12 ft, 14 ft, 17 ft
 - Weights: 6.9 tons, 7.8 tons, 11.3 tons
- ~ 14 magnet power and 16 cooling water connections per assembly



Material for Disposal

Item Description	Weight [tons]	Volume [cu yd]	Type of Waste	Quantity	Type of Containers
Girder assemblies	1811	1449	Low level rad	10	B-25 bin
			Suspension metals	176	40 cu yd dumpster
Power cables	30	20	Suspension metals	4	20 cu yd dumpster
DC Converter electronics	46	104	Electronics recycling	5	40 ft semi-trailer
Other electronics	24	88	Electronics recycling	8	40 ft semi-trailer
Totals	1911	1661			

NOTE: The numbers of bins, dumpsters, and semi-trailers were calculated by volume and adjusted by weight capacity.



Magnet/Support Assembly Installation

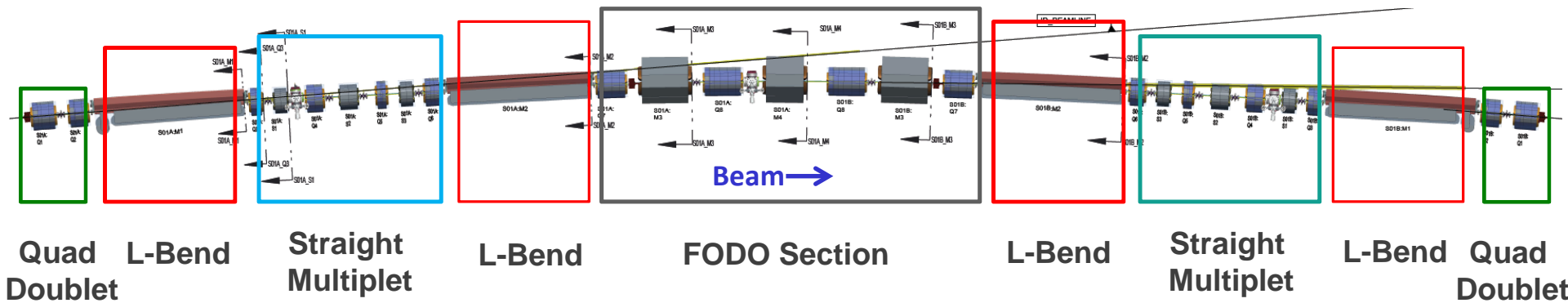

- FODO System - Four quadrupoles, three bending magnets, total weight – 57,900 pounds
- Straight Multiplet System - Four quadrupoles, three sextupoles, total weight – 25,800 pounds
- Quad Doublet System - Two quadrupoles, total weight – 9,400 pounds
- L-Bend (2 styles) - One bending magnet, total weight – 2,500 pounds



Storage Ring Installation

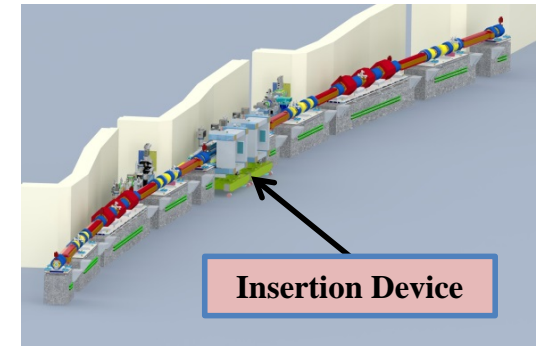
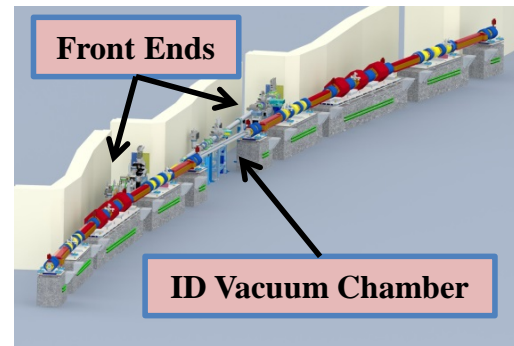
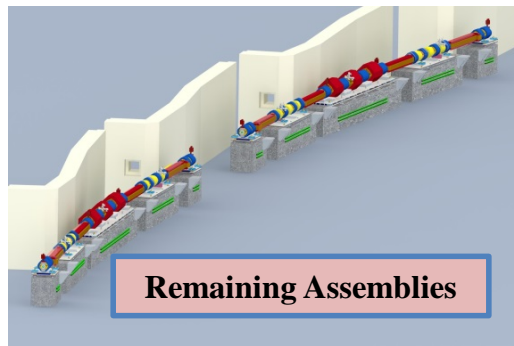
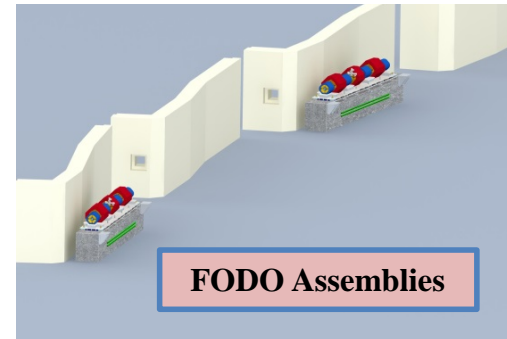

- Grout assemblies to floor
- Complete magnet assembly fine alignment
- Perform final alignment after storage ring is closed and temperature stabilizes

- Complete vacuum connections
- Complete cabling for magnets, vacuum, controls and diagnostics
- Install ID vacuum chambers
- Install front ends

- Install insertion devices
 - Planar undulators shown
- This completes mechanical component installation in the storage ring



Main Installation Tasks

- Storage ring tunnel
 - Re-establishment/checking of survey monument system
 - Installation of magnet/support/vacuum assemblies
 - Installation of the front ends
 - Installation of the insertion devices

- Mezzanine
 - Installation of cabling from the electrical racks to the storage ring equipment
 - Installation of power converters, new diagnostics, controls and vacuum electronics
 - Mezzanine installation will occur in parallel with storage ring installation.
 - Generally this work will be performed by two person teams that are distributed around the mezzanine.



Storage Ring Installation

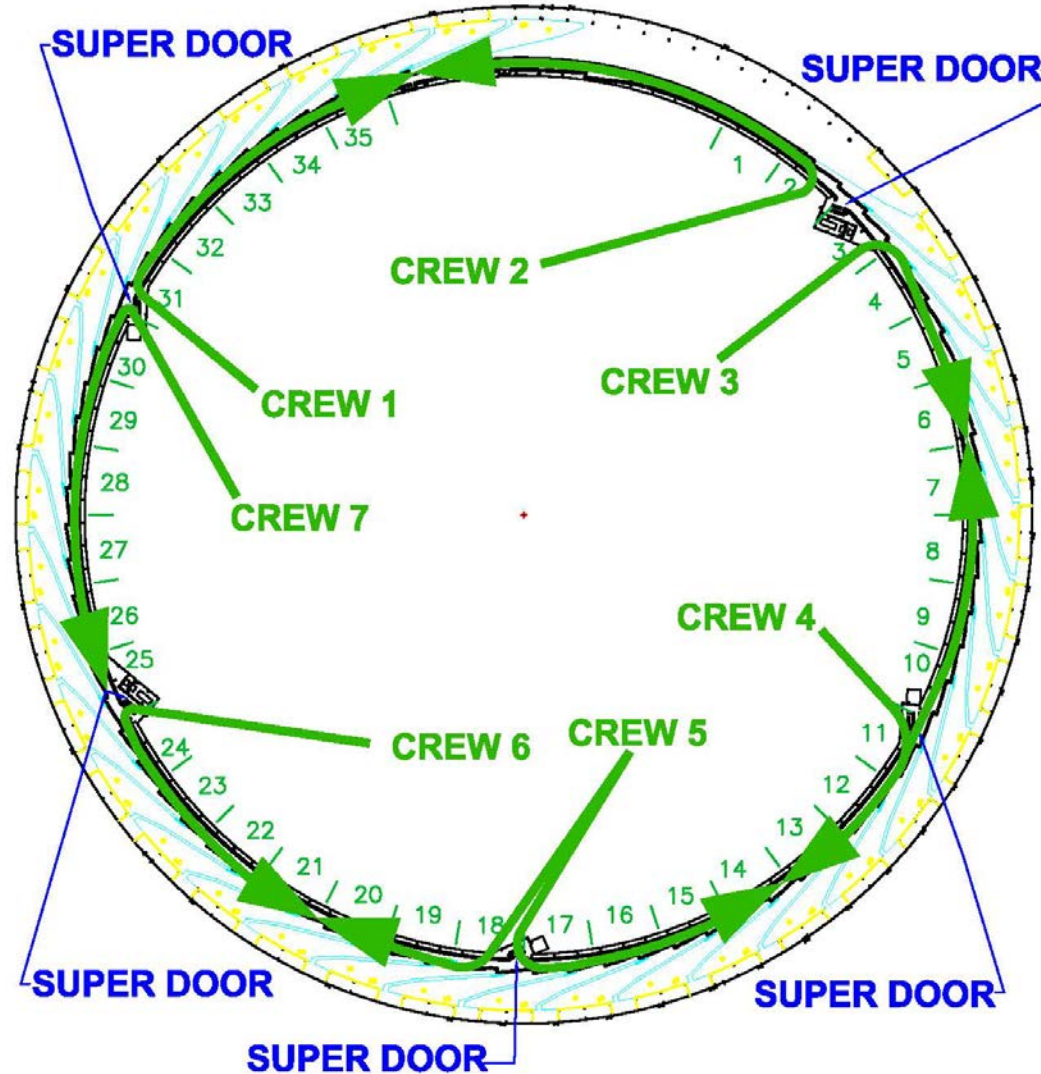

Installation crews will share super doors without interference. Equipment to be installed for the day's work will be staged outside of the super doors (infield area).

Staging pads at the super doors and temporary cover may be needed.



Removal and Installation Assumptions

■ Removal and Installation

- Planning assumes two shifts and a five day work week.
- For the purposes of our working model, we are assuming 40 identical sectors.
- A large fraction of the work can be performed by a contractor.

■ Removal

- Cooling water and HVAC systems will not require major rework during the installation period.
- Removed tunnel and mezzanine equipment will be stored elsewhere on site for disposal at a later date.

■ Installation Assumptions

- All components to be installed must be assembled, tested and staged prior to the start of the removal and installation period.
- Installation is considered complete after system testing without beam has been done.

■ Integrated System Testing Assumptions

- Effort is based on NSLS-II actuals.



Effort Summary

Removal Activity	Person-Hours
IDs and Front Ends	9,658
Storage Ring	37,300
Mezzanine Electronics	11,640
Total	58,598

This is roughly 98 people per shift for two months

Two shifts, five days per week. Crews distributed around mezzanine and storage ring.

This is roughly 100 people per shift for seven months

Installation Activity	Person-Hours
IDs and Front Ends	43,446
Storage Ring	69,594
Mezzanine Electronics	66,689
Integrated Testing without Beam	30,000
Total	209,729



Overview - Removal and Installation Schedule

TASK	Removal		Installation						
	Month 1	Month 2	Month 3	Month 4	Month 5	Month 6	Month 7	Month 8	Month 9
Remove IDs and front ends	■								
Remove mezzanine electronics	■								
Remove magnet girder assemblies	■								
Prepare tunnel surfaces		■							
Install mezzanine electronics			■						
Install new magnet girder assemblies			■						
Make vacuum and mechanical connections			■						
Install front ends			■						
Install insertion devices							■		
Final alignment								■	
Integrated system testing							■		

- Above schedule represents our bottoms up plan using five crews for storage ring removal and seven crews for storage ring installation.
- Plan was reviewed in March, 2014
 - Review committee felt that "Based on these presentations and follow-up discussions, the committee members believe that the SR equipment removal and installation plans are well developed and achievable."



Comparison to Other Storage Ring Removal and Installation Projects

Light Source	SR Circum. (m)	Remove Duration	Install Duration	Notes
SSRL/SPEAR3	234	5 weeks	27 weeks	Similar scope to APSU (1/5 length), Complete ring replacement, 1 access point
NSLS II	792	N/A	128 weeks	Limited by equipment availability
PETRA III	2304	~12 weeks	~24 weeks	1/8 of 2304 m ring removed and replaced (~300 m)
ESRF II	844	48 weeks		Planned; 20 months stop to start for user operations
MAX IV	528	N/A	52 weeks	Planned
Pohang	282	12 weeks	12 weeks	Complete; 6 month commissioning
APS-U	1104	8 weeks	28 weeks	Planned; 5 access points

We have also looked at similar projects to get a “top down” feel for the reasonableness of our planned schedule. SPEAR3 project had a similar scope but was about one-fifth the length of APS.

Summary of Space Requirements

	Disposition Facility		ID Processing Building	MRAS Building	CRATS Building
	Enclosed	Outdoor			
Square Footage	6,060 ft ²	40,550 ft ²	15,860 ft ²	55,025 ft ²	19,400 ft ²
10% un-programmed contingency space	606 ft ²	4,055 ft ²	1,586 ft ²	5,503 ft ²	1,940 ft ²
Total Square Footage	6,666 ft²	44,605 ft²	17,446 ft²	60,528 ft²	21,340 ft²

We are investigating options on site and off site to meet these needs. Some or all of ID processing, MRAS and CRATS could be consolidated in one area

- It is critical that we have sufficient space so that all items needed for installation can be tested and staged ready-for-installation before the start of the installation period.
- There is no time to play catch up.
- Space is planned to facilitate training of personnel.



Commissioning

- Survey was performed to see if 3 month commissioning is sensible.
- We surveyed recently-commissioned light sources to understand their experience.
 - “Recently-commissioned” was defined as within the last 10-15 years.
 - Facilities and Respondents
 - ALBA, BESSY-II, CLS, DLS, PLS-II, SOLEIL, SSRF, SPEAR3
 - Scheduled commissioning for projects ranged between 4 and 12 months.
 - Shift schedule was mostly 24/7.
 - All but one facility completed commissioning in less than the scheduled time, five of the seven responding facilities reported commissioning in 4 months or less.

-full report presented by M. Borland, DLSR 2014



Risks / Challenges

Risks	Mitigation
Tight schedule	Early planning, extensive practice on sector mock-up, regular reviews
All equipment is not available for installation on day 1	Ensure that equipment is available on day 1 by logistics planning and procurement tracking.
Inadequate storage space	Space planning is well underway. Space needs have been estimated. Follow through.
Accidents during outage	Practice and training on sector mock-up. Provide on-site nursing coverage to help reduce severity of injuries.
Insufficient work force	Early work force planning. Personnel ramp-up starts during pre-installation period. Use of contractors where appropriate.
Labor disputes	Have dedicated managers working with crafts to work out disputes in a timely manner. Early Davis-Bacon determination
Accelerator Readiness Review delays	Interface early with review team to avoid delays.



Conclusions

- We recognize that minimizing the down time is critical to our users.
- We have assembled a preliminary plan to accomplish the removal, installation and commissioning within twelve months.
- We are continuing to refine the plan and to learn from others.



BACK-UP



Commissioning

TAIWAN PHOTON SOURCE

“Commissioning and the First Light”

After four and half years of construction and **4 months of hardware testing and improvement**, the TPS finally initiated its commissioning of the in-house-built booster ring on December 12, 2014. The electron beam was accelerated to 3 GeV on December 16 and the booster’s efficiency has reached more than 60% on the following day.

The storage ring was also designed by the NSRRC staffs and aimed to be one of the brightest light sources in the world. After all of hardware testing and improvement were ready, **the commissioning of the storage ring began on December 29. On the next day**, the commissioning team injected the beam into the storage ring and the electrons **completed circulating its first turn**, indicating that the design quality, the precision of the magnets and the well-prepared integration has reached the world upmost standard. **The 3 GeV electron beam** with a stored current of 1 mA was achieved and the first synchrotron light was observed in the early afternoon **on December 31**, then the stored current **reached 5 mA in the late afternoon**, right before the shut-down for the new year holiday.”



Commissioning

- Definition of the commissioning period used in the survey:
 - Begins when beam is first injected into the ring
 - Ends when ring is capable of supporting meaningful beamline commissioning, which generally requires:
 - Ring can routinely store a significant fraction of the planned initial operating current for periods of 8 hours or more.
 - Lattice and emittance are essentially at initial design configuration/values.
 - Lifetime is workable.
 - Orbit and stability are workable.
 - One or more ready-to-use insertion devices are in place.
- APS-U is committed to providing useful beam to our users at the end of the commissioning period; exact definition is under discussion.

